

This Page Is Inserted by IFW Operations
and is not a part of the Official Record

BEST AVAILABLE IMAGES

Defective images within this document are accurate representations of the original documents submitted by the applicant.

Defects in the images may include (but are not limited to):

- BLACK BORDERS
- TEXT CUT OFF AT TOP, BOTTOM OR SIDES
- FADED TEXT
- ILLEGIBLE TEXT
- SKEWED/SLANTED IMAGES
- COLORED PHOTOS
- BLACK OR VERY BLACK AND WHITE DARK PHOTOS
- GRAY SCALE DOCUMENTS

IMAGES ARE BEST AVAILABLE COPY.

**As rescanning documents *will not* correct images,
please do not report the images to the
Image Problem Mailbox.**

Code: 1052-38174

JAPANESE PATENT OFFICE

PATENT JOURNAL

KOKAI PATENT APPLICATION NO. SHO 62[1987]-47359

| | |
|-------------------------------|------------------------------|
| Int. Cl. ⁴ : | A 61 H 23/02 A 61 B 17/00 |
| Sequence Nos. for Office Use: | 7916-4C 6761-4C |
| Application No.: | Sho 60[1985]-187196 |
| Application Date: | August 28, 1985 |
| Publication Date: | March 2, 1987 |
| Number of Inventions: | 1 (Total of 5 pages) |
| Examination Request: | Requested |

ULTRASOUND STIMULATOR FOR BONES

| | |
|------------|---|
| Inventor: | Mitsuyoshi Hirafuku c/o Aroka K.K. 6-22-1 Mure, Mitaka-shi Akira Kotaniya c/o Aroka K.K. 6-22-1 Mure, Mitaka-shi |
| Applicant: | Aroka K.K. 6-22-1 Mure, Mitaka-shi |

[There are no amendments to this patent.]

Claims

1. An ultrasound stimulator for bone that is characterized in that it comprises a transmission pulse generator that generates an ultrasound transmission pulse used to stimulate bone tissue, and a transducer that generates ultrasound based on the aforementioned transmission pulse; wherein the bone tissue is irradiated with the ultrasound stimulation pulse wave in a desired repeating cycle.

2. An ultrasound stimulator for bone that is characterized, as the device described in Claim 1, in that the aforementioned transmission pulse signal is synchronized with the heartbeat so that the ultrasound irradiation process follows the pulse cycle.

3. An ultrasound stimulator for bone that is characterized, as the device described in Claim 1, in that it comprises a function generating circuit that generates a function wave that consists of a chopped wave, sine wave, or a combination thereof; wherein the transmission pulse train is amplitude modulated according to the aforementioned function wave.

4. An ultrasound stimulator for bone that is characterized, as the device described in Claims 1, 2, and 3, in that a bag filled with a fluid is situated between the aforementioned transducer and the surface of the body so as to increase the efficiency of the ultrasound irradiation process on the tissue being stimulated.

5. An ultrasound stimulator for bone that is characterized, as the device described in Claim 4, in that the fluid in the aforementioned bag is circulated so as to prevent the temperature of the fluid from rising.

Detailed explanation of the invention

Industrial application field

The present invention pertains to an ultrasound stimulator for bone, and pertains in particular to an ultrasound stimulator for bone in which a broken bone or joint, etc., is irradiated with ultrasound energy. In this manner the bone tissue is stimulated, thereby providing treatment for the broken bone or joint, etc.

Conventional Technology

In recent years techniques have been used to irradiate the heart with ultrasound, thereby stimulating the heart tissue, blood vessels, etc., so as to restore their function. Ultrasound energy is thus recognized as being effective for healing body tissues.

In addition to cardiological applications, the use of such ultrasound stimulation is expected to be beneficial for other body tissues as well. Although the biological mechanism is not clearly understood, the following have been confirmed for applications to bone tissue: it is possible to accelerate the bone formation process necessary for healing bones or joints after setting a bone fracture or performing surgery; it is possible to treat skeletal deformities and to stimulate bones in the head for correcting the alignment of the teeth, etc. Thus the effects of ultrasound stimulation are gaining recognition.

Ultrasound stimulators for bones utilizing such ultrasound stimulation have been used experimentally for the aforementioned types of broken bone treatment, etc. There is thus a demand for systems that are capable of ultrasound irradiation in a wide variety of patterns so as to increase the effectiveness of ultrasound stimulation.

Problems to be solved by the invention

Problems with the conventional technology

However, conventional types of ultrasound stimulation are performed continuously for a fixed cycle time. This type of simple stimulation technique is problematic in that it is not possible to efficiently accelerate the bone formation process, etc. In addition, they are problematic in that it is not possible to strongly impact the bone tissue to a degree that is very effective.

Objective of the invention

The present invention has been designed in light of the aforementioned problems with the conventional technology, and has the objective of providing an ultrasound stimulator for bone that is highly effective in the treatment of bone complications, wherein a type of ultrasound irradiation permitting a large range of freedom is utilized to efficiently stimulate the bone tissue.

Means for solving the problems and operations

In order to achieve the aforementioned objective, the present invention is characterized in that it comprises a transmission pulse generator that generates an ultrasound transmission pulse used to stimulate bone tissue, and a transducer that generates ultrasound based on the aforementioned transmission pulse; wherein the bone tissue is irradiated with the ultrasound stimulation pulse wave in a desired repeating cycle.

The use of this type of structure makes it possible to irradiate the bone tissue with ultrasound stimulation pulse waves in a variety of repeating cycles, optimized for bone tissue conditions occurring in a variety of bone complications.

Application examples

Suitable application examples of the present invention will be described below with reference to the figures.

Figure 1 illustrates the basic first application example of the ultrasound stimulator for bone. A transmission pulse is supplied from a transmission pulse generator (12) to a transducer (10) that generates ultrasound.

The present invention is characterized in that ultrasound pulse irradiation is carried out in a desired repeating cycle, instead of using a continuous ultrasound wave. Thus a pulse generating circuit (14) inside the aforementioned transmission pulse generator (12) generates transmission pulses.

The aforementioned transmission pulse generator (12) comprises the aforementioned pulse generating circuit (14), as well as an oscillator (16) and an amplifier (18). The output of the pulse generating circuit (14) is provided to the oscillator (16) that generates a high frequency, where it is converted into a high frequency pulse in a fixed repeating cycle. The output of the aforementioned oscillator (16) is supplied to the amplifier (18), where it is amplified to a maximum prescribed output and then provided to the transducer (10).

The aforementioned pulse generating circuit (14) can be used to alter as desired the repeating cycle in which the pulse wave is transmitted. Thus it is possible to select the repeating cycle that is best for the conditions of the particular bone tissue being treated. Thus the stimulating ultrasound emitted from the transducer (10) forms a stimulation pulse wave that is optimized to a variety of bone complications. This has a strong and effective impact on various types of bone tissue complications. Thus the objective of effective treatment is achieved. It should be noted that the stimulating ultrasound is set in a frequency range of several hundred kHz to several MHz.

A second application example will now be discussed, wherein the aforementioned repeating cycle is a cycle considered effective for various bone tissue complications, i.e., the heartbeat cycle.

As shown in Figure 2, in the 2nd application example the transmission pulse generator (12) is connected to a heartbeat cycle circuit (20), which supplies the transducer (10) with a transmission pulse synchronized to the heartbeat. Thus a signal synchronized to the heartbeat is provided to the pulse generating

circuit (14), after which it is provided to the transducer (10) through the oscillator (16) and amplifier (18) in the manner described above. Thus the stimulating ultrasound generated by the transducer (10) is synchronized to the heartbeat.

The reference heartbeat signal of the aforementioned heartbeat cycle circuit (20) can be obtained from a pulsometer, or obtained from an electrocardiograph or heart rate meter. Thus the pulse of the patient being treated is sensed to provide highly efficient ultrasound irradiation synchronized to the pulse.

The rate of blood flowing through capillaries as it circulates through the tissue surrounding the bones fluctuates according to the heartbeat period, and the bone tissue becomes active in response to fluctuations in the blood flow. Thus it is clear that when the ultrasound stimulation is synchronized to the heartbeat as in the 2nd application example, the impact on the tissue is increased tremendously.

In this manner it is possible to apply an effective stimulus to the bone tissue in a variety of different conditions. In addition, it is possible to provide stimulus conditions optimized for the particular objectives by varying the strength of the ultrasound stimulation. Figure 3 illustrates the third application example of the device of the present invention, with which it is possible to alter the ultrasound stimulation strength by modulating the transmission pulse train amplitude.

In the figure, an amplitude modulator (22) is situated between the amplifier (18) and the oscillator (16) in the

transmission pulse generator (12). In addition, a function wave generator (24) is connected to the aforementioned amplitude modulator (22).

The aforementioned function wave generator (24) consists of an exponential function wave generator (26), a chopped wave generator (28), a sine wave generator (30), and a compound function wave generator (32). These generators are used to form a variety of different amplitude modulated waves.

More specifically, as shown in Figure 4(a), with the exponential function wave generator (26), the exponent of the exponential function is set as positive or negative, and values are set for a time constant α and effective time t in order to generate an exponential function modulating wave $e^{\pm\alpha t}$.

As shown in Figure 4(b), with the chopped wave generator (28), the rising or falling slope and the corresponding time region are set in order to generate the desired modulation with a chopped waveform.

In addition, as shown in Figure 4(c), with the sine wave generator (30), the sine wave base period and start and end phases are set and an effective phase angle is selected in order to generate the desired modulating wave with a sinusoidal waveform (fragmentary waveform).

Next the compound function wave generator (32) takes as input the output signals of the aforementioned exponential function wave generator (26), chopped wave generator (28), and sine wave generator (30), and outputs a modulating wave with a compound waveform such as that shown in Figure 4(d).

The modulating waves thus generated through the various generators are passed through a switch (33) to be input to the amplitude modulator (22). The amplitude modulator (22) amplitude modulates the peak value of the high frequency pulse train input from the oscillator (16) according to the corresponding modulating wave, then inputs these to the amplifier (18). Thus as shown in Figure 4(e), the transmission pulse train output from the transmission pulse generator (12) is made into a transmission pulse train, the maximum pulse peak of which is amplified to the strength set as the maximum value for the modulating wave. Thus the ultrasound wave irradiated from the transducer (10) has a variable strength.

Thus in the 3rd application example it is possible to irradiate the bone tissue with a variety of stimulating ultrasound wave strengths. For this reason, it is possible to provide the bone tissue with ultrasound stimulation suitable for restoring the functions of the bone tissue, such as stimuli that change gradually or abruptly. Thus it is possible to provide a highly effective stimulus optimized to the particular bone complication.

It should be noted that the transducer (10) to be used is the same as the commonly used type of medical ultrasound vibrator. Thin electrodes are attached to the sides of the electricity-vibration conversion elements, and ultrasound vibration absorbers are attached to their rear sides. In addition, an insulating thin film covers the entire unit. The front side of the irradiation opening is covered with a thin film consisting of a material that can be easily matched to the [illegible] acoustic impedance of the body.

The actual method used to irradiate bone tissue with the stimulating ultrasound will now be described.

The basic procedure is to apply the transducer (10) to the skin surface and to irradiate the area of bone tissue to be treated with ultrasound by means of a sector or linear method. However, there are many cases where it is not possible to firmly apply the transducer (10) to the surface of the body because the surface is uneven.

As shown in Figure 5, in such cases a bag (34) filled with a fluid may be placed between the transducer (10) and the body (36) (e.g., the foot or arm). This is then securely fastened by means of arms (38) and (40) attached to the transducer (10). In this manner it is possible to prevent the drop in the ultrasound wave efficiency resulting from air between the body surface and the transducer (10).

In addition, the aforementioned bag (34) is designed so that the fluid it contains is circulated in order to maintain it at a constant temperature at all times. As a result, in cases where the stimulating ultrasound irradiation process requires a relatively long period of time, it is possible to prevent the temperature of the liquid from rising inside the bag (34). Thus it is possible to provide effective stimulating ultrasound treatment without causing the patient pain.

Effects of the invention

As described above, with the present invention, the ultrasound used to stimulate bone tissue consists of pulsed ultrasound waves set to a desired repeating cycle. Thus it is

possible to accelerate the process of bone formation by applying a very efficient stimulus to the bone tissue. This is effective for healing bones or joints after setting a bone fracture or performing surgery.

In addition, by setting the desired repeating cycle, it is possible to provide a highly flexible stimulus to the bone tissue, optimized for a wide variety of bone afflictions. In this manner it is possible to provide treatment permitting a rapid recovery of functions.

Brief explanation of the figures

Figure 1 is an explanatory diagram that illustrates a suitable 1st application example of the ultrasound stimulator for bone of the present invention.

Figure 2 is an explanatory diagram that illustrates the 2nd application example that pertains to the present invention.

Figure 3 is an explanatory diagram that illustrates the third application example that pertains to the present invention.

Figure 4 is an explanatory diagram that illustrates modulating waves that vary the strength of the ultrasound wave.

Figure 5 is an explanatory diagram that illustrates a bag that is placed between the transducer and the surface of the body.

- 10. Transducer
- 12. Transmission pulse generator
- 20. Heartbeat cycle circuit
- 24. Function wave generator
- 26. Exponential function wave generator

- 28. Chopped wave generator
- 30. Sine wave generator
- 32. Compound function wave generator
- 34. Bag
- 36. Body

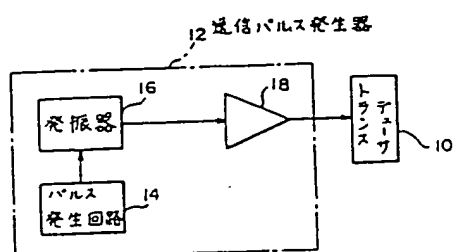

Figure 1

- Key: 10 Transducer
12 Transmission pulse generator
14 Pulse generating circuit
16 Oscillator

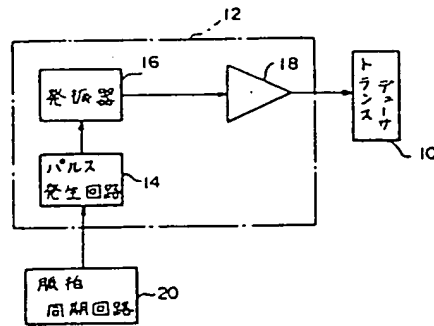

Figure 2

- Key: 10 Transducer
 14 Pulse generating circuit
 16 Oscillator
 20 Heartbeat cycle circuit

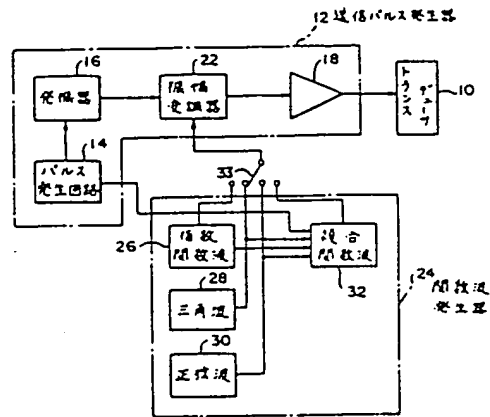

Figure 3

- Key: 10 Transducer
 12 Transmission pulse generator

- 14 Pulse generating circuit
- 16 Oscillator
- 22 Amplitude modulator
- 24 Function wave generator
- 26 Exponential function wave generator
- 28 Chopped wave generator
- 30 Sine wave generator
- 32 Compound function wave generator

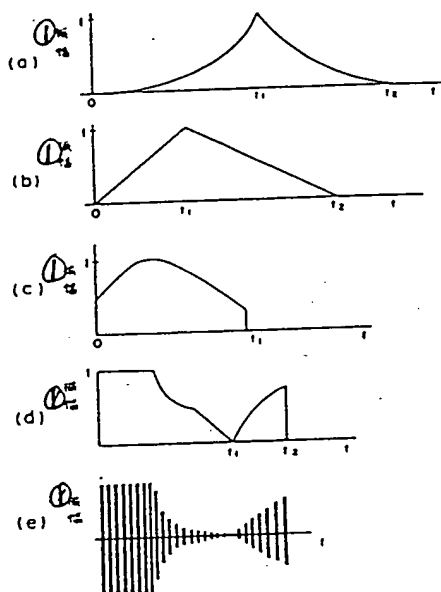

Figure 4

Key: 1 Amplitude

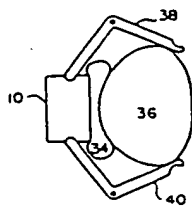

Figure 5